

TS-800/1000WNV

HIGH SPEED FOLDING AND GLUING MACHINE

SPECIFICATIONS

Stock Type	Cardboard, E-flute corrugated and decorated board.
Folding Capability	Standard Folding boxes, Double sides boxes, Crash-lock Bottom boxes, 4/6 corners
Machine Speed	Max. 300 M /min
Max. Blank width	800mm / 1000mm
Pre-Folding	No. 1 Creasing line 180° · No. 3 Creasing line 135°
Feeding	Automatic and continuous feeding.
Glue Type	(For glue pot) Water based glue
Power Required	15KW
Machine Weight(approx.)	800: 6,500kgs, 1000: 8,500kgs

BLANK SIZE

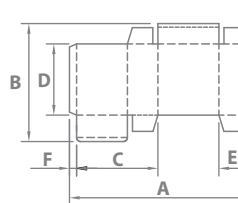

MODEL	TS-800	TS-1000
A	M 800 m 150	1000 150
B	M 600 m 100	700 100
C	M 380 m 60	490 60
D	M 450 m 50	600 50
E	M 190 m 25	245 25
F	M 30 m 10	30 10

Straight line

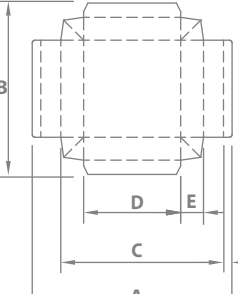

MODEL	TS-800	TS-1000
A	M 750 m 110	850 110
B	M 650 m 100	700 100
C	M 550 m 110	700 110
D	M 500 m 70	540 70
E	M 70 m 20	70 20
F	M 50 m 12	47 12

Both sides

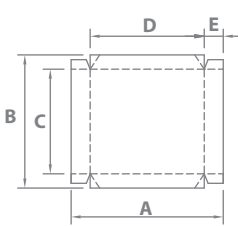

MODEL	TS-800	TS-1000
A	M 650 m 160	800 160
B	M 550 m 180	600 180
C	M 500 m 120	550 130
D	M 400 m 100	600 100
E	M 100 m 30	100 30

4-corner

FLOOR PLAN

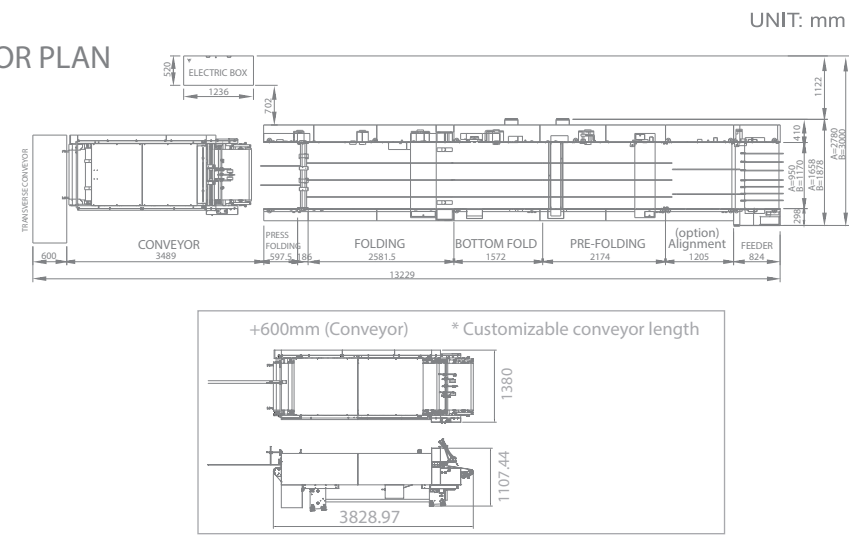
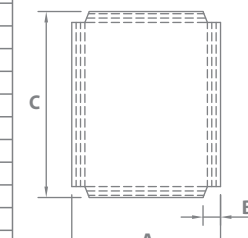
MODEL	TS-800	TS-1000
A	M 650 m 200	850 250
B	M 50 m 25	50 25
C	M 550 m 180	600 180

Both sides

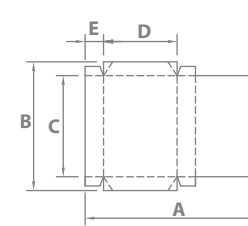

MODEL	TS-800	TS-1000
A	M 650 m 270	800 270
B	M 550 m 180	600 180
C	M 500 m 120	500 120
D	M 280 m 100	360 100
E	M 100 m 30	100 30

4-corner

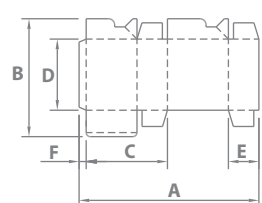

MODEL	TS-800	TS-1000
A	M 650 m 200	850 250
B	M 50 m 25	50 25
C	M 550 m 180	600 180

Lock bottom

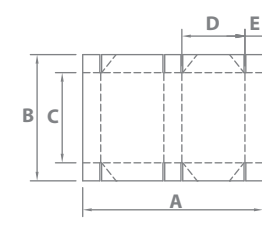

MODEL	TS-800	TS-1000
A	M 650 m 270	800 270
B	M 550 m 180	600 180
C	M 500 m 120	500 120
D	M 280 m 100	360 100
E	M 100 m 30	100 30

6-corner

SBL

TSAIR SHUENN MACHINERY IND CO., LTD.
SBL MACHINERY CO., LTD.

108, Sec. 1, Ganyuan St., Shulin Dist.,
New Taipei City 23880, Taiwan
Tel: +886-2-2680-2199 Fax: +886-2-2680-2197
http://www.sbl.tw E-mail: info@sbl.tw



STS MACHINERY CO., LTD.

Xi-Cheng Industrial Area2,
Heng Li Town, Dongguan City, China. 523465
Tel: +86-769-82180588 Fax: +86-769-81180989
http://www.stsmachinery.com



TS-800/1000WNV

HIGH SPEED FOLDING AND GLUING MACHINE

SBL

EN-F-800/1000-002-051019
Specifications are subject to change without notice

TS-800/1000WNV

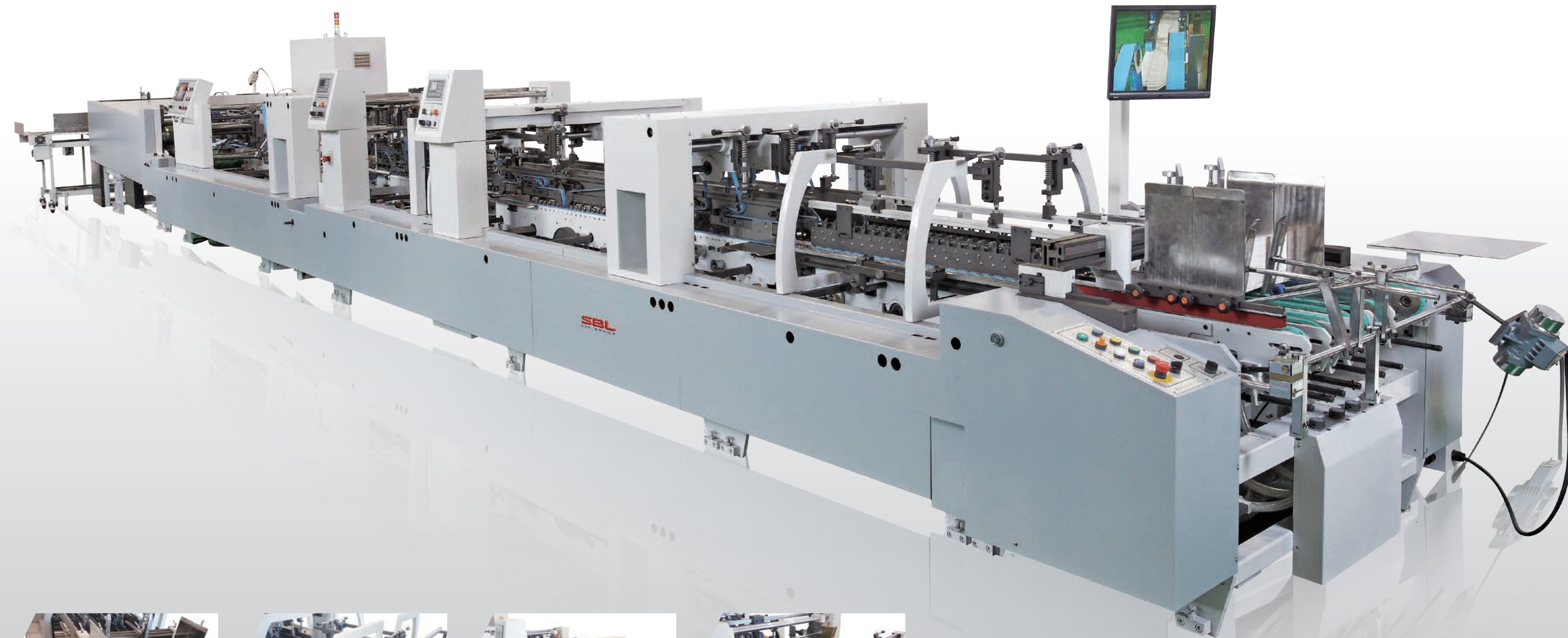

· Feeder



· Alignment(option)



· Pre-folding



· Bottom folding



· Lower guling



· Final folding



· Press folding

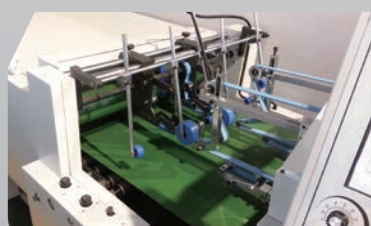

· Conveyor

FEATURES

1. Equipped with wireless remote control for easy operation and high mobility.
2. Large full color stacking monitor / CCD system and touch screen setting monitor.
3. Individually adjustable feeding belts without suction. (Suction device is optional)
4. Pneumatic lifter on feeder and pattern feeding mechanism can easily adjust for different sheets width.
5. Position indicator on all carriers to ensure easy and quick change carrier position.
6. Top belt drive system in pre-fold section and final fold section. Can run either carton board or E flute corrugated board job more precisely.
7. Pattern aluminum pressing board with fixing clips make job changing quicker and easier.
8. Pre-fold left/right upper carrier and final fold left/middle/right upper carrier can adjust independently.
9. PLC program control system with two servo motor backing fold system, suitable for 4 & 6 point boxes, cake, gift, lock bottom boxes, double wall boxes and standard straight line boxes production, Modulize options can be adapted to run each different appliance easily.
10. Heavy duty inverter for main motor and timing belt for driving motor.
11. Max. machine speed of 300m/min, high efficiency, low noise, durable and easy to maintain.
12. Standard lower and topper glue pot unit on both sides, easy to remove, fix and clean.
13. Adjustable pressing roller after final fold section to reach different flatness requirements.
14. Standard machine include independent electrical cabinet, touch screen monitor setting system, volume setting and kicker device.
15. Unique conveyor design help smoother paper stacking and high efficiency.

